

Pressarmatur Typ XPRUS / Fitting type XPRUS					
Rohrstutzen mit 45°-Bördel, UNF-Überwurfschraube					
Pipe stud with 45° flare, UNF union nut					
Art. Nr.	Bezeichnung	Standard	DN	G1	S1
Art. N°	Description				
225.050	XPRUS 06 7/16"	•	06	7/16"	12
225.051	XPRUS 06 1/2"		06	1/2"	14
225.055	XPRUS 08 7/16"		08	7/16"	12
225.056	XPRUS 08 1/2"	•	08	1/2"	14
225.057	XPRUS 08 5/8"		08	5/8"	17
225.060	XPRUS 10 7/16"		10	7/16"	12
225.061	XPRUS 10 1/2"		10	1/2"	14
225.062	XPRUS 10 5/8"	•	10	5/8"	17
225.063	XPRUS 10 11/16"		10	11/16"	19
225.065	XPRUS 12 3/4"	•	12	3/4"	19

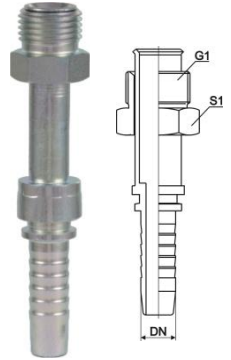

45° Pressarmatur Typ XPKUS ..14 / 45° fitting type XPKUS ..14					
Rohrstutzen mit 45°-Bördel, UNF-Überwurfschraube					
Pipe stud with 45° flare, UNF union nut					
Art. Nr.	Bezeichnung	Standard	DN	G1	S1
Art. N°	Description				
225.090	XPKUS 10 7/16" /4		10	7/16"	12
225.091	XPKUS 10 1/2" /4		10	1/2"	14
225.092	XPKUS 10 5/8" /4	•	10	5/8"	17
225.093	XPKUS 10 11/16" /4		10	3/4"	19

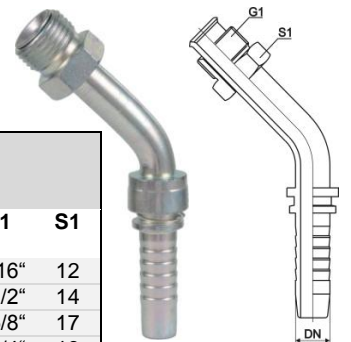

90° Pressarmatur Typ XPKUS..19 / 90° fitting type XPKUS ..19					
Rohrstutzen mit 45°-Bördel, UNF-Überwurfschraube					
Pipe stud with 45° flare, UNF union nut					
Art. Nr.	Bezeichnung	Standard	DN	G1	S1
Art. N°	Description				
225.100	XPKUS 06 7/16" /9	•	06	7/16"	12
225.101	XPKUS 06 1/2" /9		06	1/2"	14
225.105	XPKUS 08 7/16" /9		08	7/16"	12
225.106	XPKUS 08 1/2" /9	•	08	1/2"	14
225.107	XPKUS 08 5/8" /9		08	5/8"	17
225.110	XPKUS 10 7/16" /9		10	7/16"	12
225.111	XPKUS 10 1/2" /9		10	1/2"	14
225.112	XPKUS 10 5/8" /9	•	10	5/8"	17
225.113	XPKUS 10 11/16" /9		10	11/16"	19
225.115	XPKUS 12 3/4" /9	•	12	3/4"	19

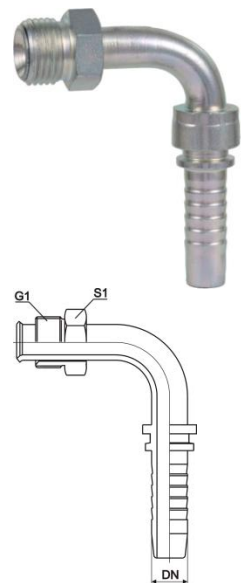

Standard Standardgröße / Standard size
DN Durchmesser Nominal / Diameter nominal
G1 Gewinde / Thread
S1 Schlüsselweite / Hexagon